

INSTRUCTION MANUAL SP12

Corally[®]

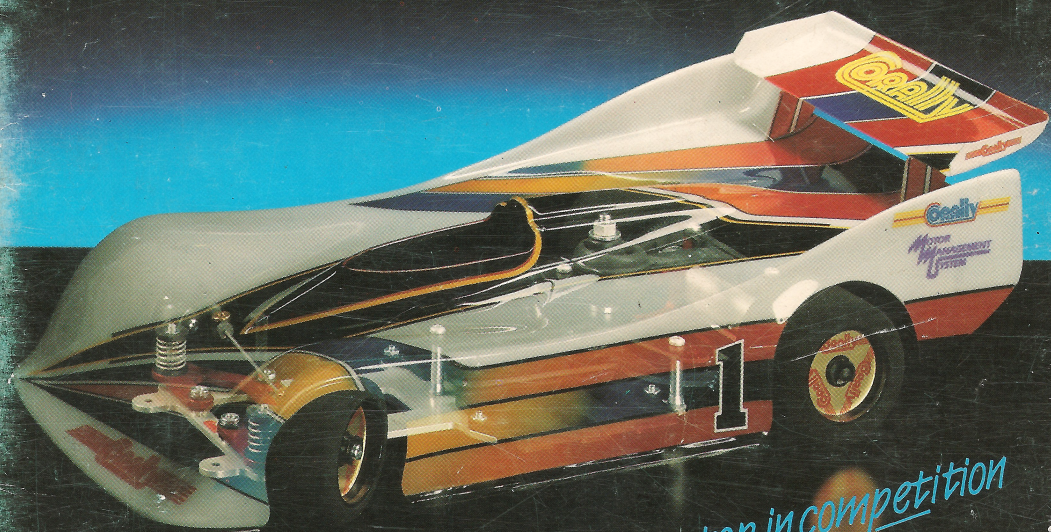

top in competition

SP12

ORALLY[®]

top in competition

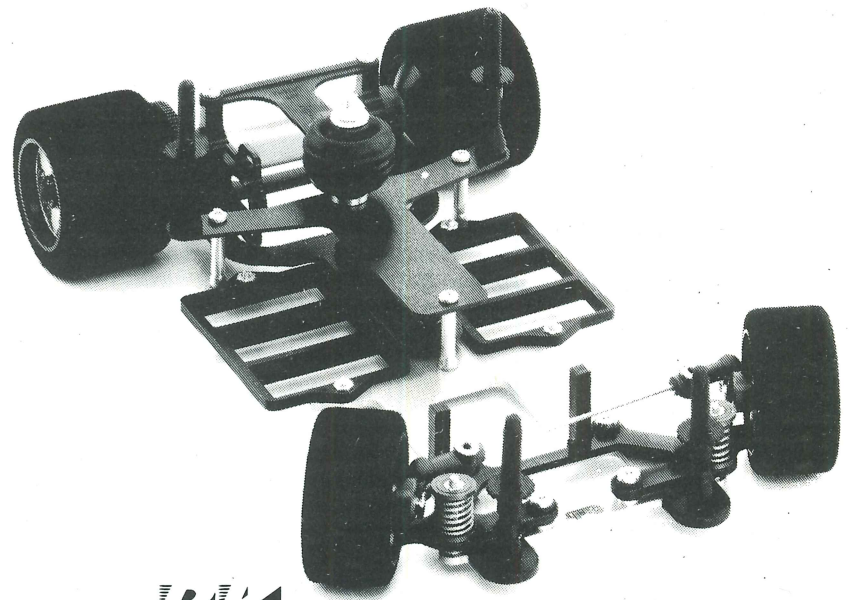

PK

PK MODEL RACING

Toulonselaan 58

3312 EV Dordrecht-Holland

Phone 078-132324. Fax 078-134595

EXPLODED VIEW CORALLY SP12

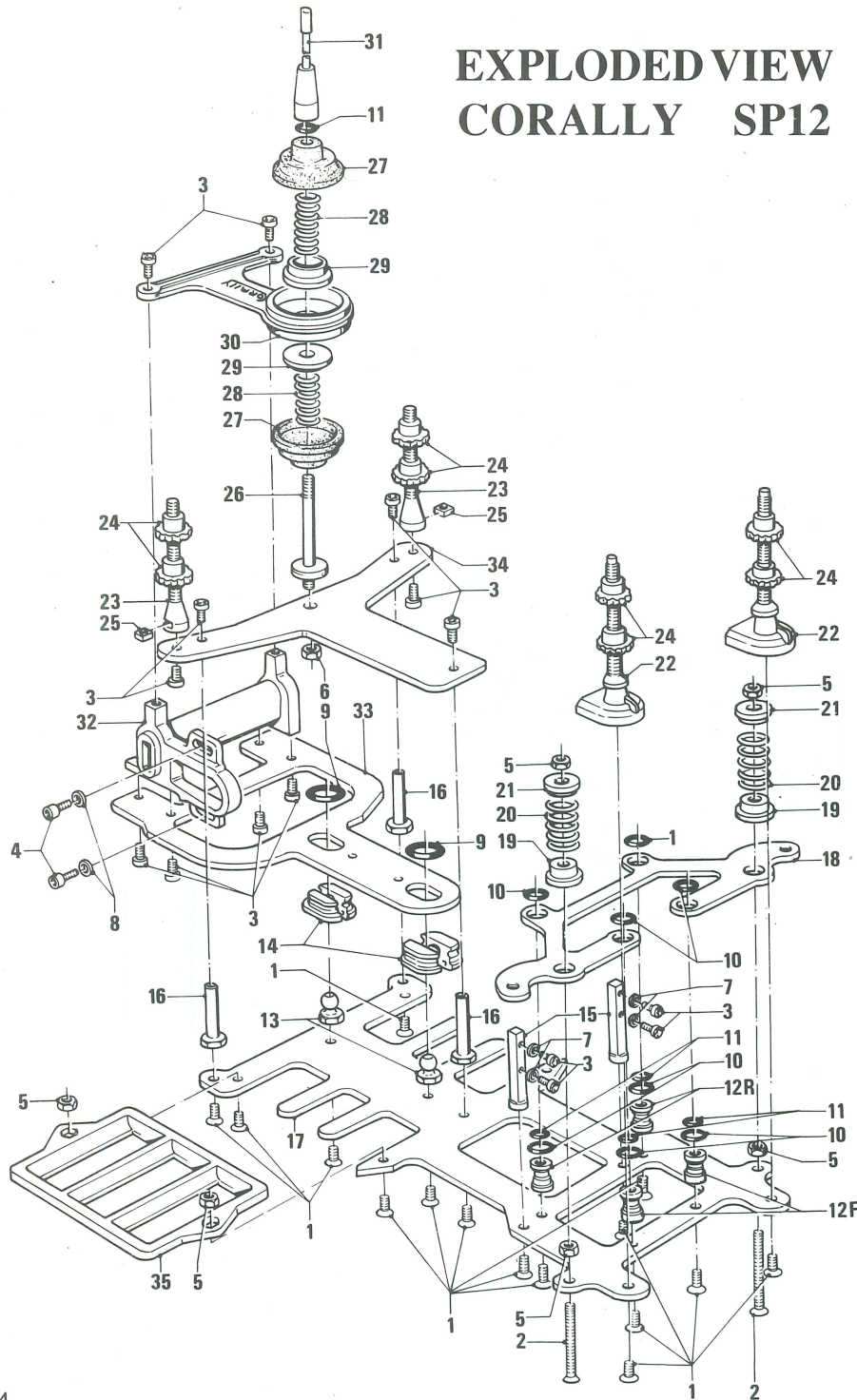

Draw no	Description	Qty	SP12	PRO10	Part no.	List Price
	SCREW SPARE SET		x	x	76071	Fl. 18.00 \$ 8.00
1	Screws 3 x 8 F.H.	10	x	x		
2	Screws 3 x 30 F.H.	2	x			
	Screws 3 x 35 F.H.	2		x		
3	Screws 3 x 6 R.H.	6	x	x		
4	Motor screws 3 x 6	2	x	x		
5	Nuts M 3	4	x	x		
6	Nuts M 5	1	x	x		
7	Washers 3 mm alloy	6	x	x		
8	Washers 3 mm steel	2	x	x		
9	O-Rings T-Bar	2	x	x		
10	O-Rings 5 mm	4	x	x		
11	O-Rings 3 mm	4	x	x		
	O-Rings 2 mm	3	x	x		
64	King pin shims	6	x	x		
68	Screws 2 x 6	2	x	x		
72	Screws 2 x 10	1	x	x		
75	Nuts M 2	2	x	x		
	Rear axle shims	2	x	x		
	PIVOT SET FRONT BEAM		x		75061	Fl. 9.95 \$ 4.50
12f	Front beam pivot long	1	x			
12r	Front beam pivot short	1	x			
10	O-rings 5 mm	4	x	x		
11	O-rings 3 mm	4	x	x		
1	Screws 3 x 8 F.H.	2	x	x		
	PIVOT SET T-BAR		x	x	75290	Fl. 14.95 \$ 6.50
13	T-Bar pivots	2	x	x		
14	T-Bar sockets	4	x	x		
9	O-Rings T-Bar	2	x	x		
1	Screws 3 x 8 F.H.	2	x	x		
	SERVO POST SET		x	x	75491	Fl. 12.50 \$ 5.50
15	Servo Posts	2	x	x		
1	Screws 3 x 8 F.H.	2	x	x		
3	Screws 3 x 6 R.H.	4	x	x		
7	Washers 3 mm alloy	4	x	x		

Draw no	Description	Qty	SP12	PRO10	Part no.	List Price
	RADIO TRAY POST SET		x	x	75301	Fl. 18.00 \$ 8.00
16	Radio tray posts	3	x	x		
1	Screws 3 x 8 F.H.	3	x	x		
3	Screws 3 x 6 R.H.	3	x	x		
17	CHASSIS	1	x		75001	Fl. 99.00 \$ 45.00
18	FRONT BEAM	1	x		75051	Fl. 45.00 \$ 20.00
	SPRING SET		x	x	75570	Fl. 14.95 \$ 6.50
	Front beam spacers	4	2	4		
19	Spring stops (bottom)	2	x	x		
20	Spings	2	x	x		
21	Spring stops (top)	2	x	x		
2	Screws 3 x 25 F.H.	2	x			
2	Screws 3 x 30 F.H.	2		x		
5	Nuts M 3	4	x	x		
	BODY POST FRONT		x		75700	Fl. 12.50 \$ 5.50
22	Body posts front	2	x			
24	Body post nuts	4	x			
1	Screws 3 x 8 F.H.	2	x			
	BODY POST 50 mm		x	x	75701	Fl. 12.50 \$ 5.50
23	Body posts 50 mm	2	x	x		
24	Body post nuts	4	x	x		
25	Body post inserts	2	x	x		
1	Screws 3 x 8 F.H.	2	x	x		
3	Screws 3 x 6 R.H.	2	x	x		
	BODY POST 65 mm		x	x	75702	Fl. 12.50 \$ 5.50
	Body posts 65 mm	2	x	x		
24	Body post nuts	4	x	x		
25	Body post inserts	2	x	x		
1	Screws 3 x 8 F.H.	2	x	x		
3	Screws 3 x 6 R.H.	2	x	x		

Draw no	Description	Qty	SP12	PRO10	Part no.	List Price
	BODY POST 80 mm		x	x	75703	Fl. 12.50 \$ 5.50
	Body posts 80 mm	2	x	x		
24	Body post nuts	4	x	x		
25	Body post inserts	2	x	x		
1	Screws 3 x 8 F.H.	2	x	x		
3	Screws 3 x 6 R.H.	2	x	x		
24	BODY POST NUTS	8	x	x	75710	Fl. 7.50 \$ 3.50
26	DAMPER POST	1	x		75350	Fl. 12.50 \$ 5.50
	DAMPER SET		x	x	75351	Fl. 15.95 \$ 7.00
27	Damper rubbers	2	x	x		
28	Damper springs	2	x	x		
29	Damper washers	2	x	x		
30	DAMPER PLATE	1	x	x	75380	Fl. 25.95 \$ 11.50
31	ANTI ROLL MAST	1	x		10400	Fl. 11.25 \$ 5.00
32	MOTOR POD	1	x		75151	Fl. 109.95 \$ 48.00
33	T-BAR	1	x		75201	Fl. 47.50 \$ 21.00
34	RADIO TRAY	1	x		75321	Fl. 33.95 \$ 15.00
	BATTERY HOLDERS		x	x	1617	Fl. 12.50 \$ 5.50
35	Battery holders	4	x	x		
5	Nuts M 3	8	x	x		
1	Screws 3 x 8 F.H.	8	x	x		

CORALLY SP12 FRONT SUSPENSION & DIFFERENTIAL

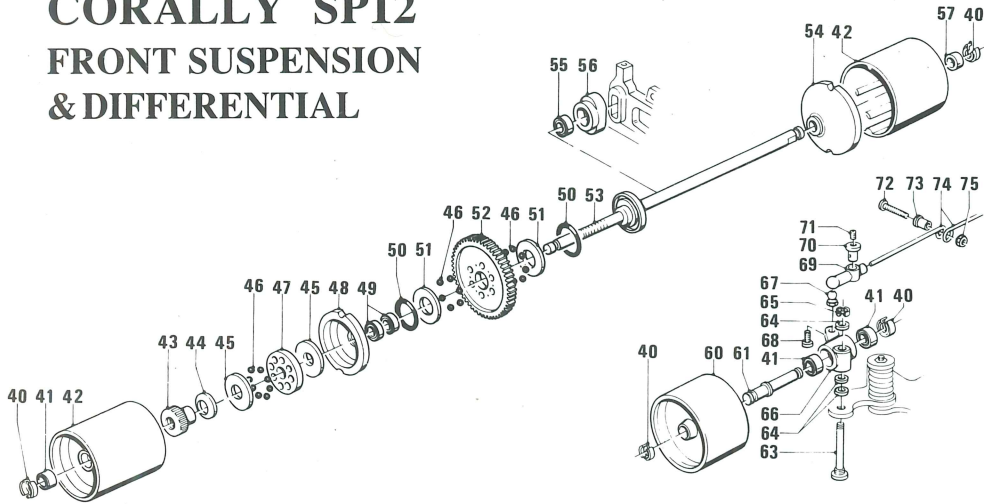

Draw no	Description	Qty	SP12	PRO10	Part no.	List Price
	CLIP SET		x	x	76061	Fl. 8.95 \$ 3.50
40	Clips 3 mm	8	x	x		
65	Clips 2 mm	3	x	x		
57	Left wheel insert	1	x	x		
41	BALL BEARINGS 5 x 9	2	x	x	1121	Fl. 27.00 \$ 12.00
42	REAR WHEEL	2	x		75811	Fl. 9.95 \$ 4.50
	DIFF. NUT SET		x	x	75920	Fl. 9.00 \$ 4.00
43	Diff. nut	1	x	x		
44	Cone washer	1	x	x		
	SPARE PARTS DIFF.		x	x	1002	Fl. 12.50 \$ 6.00
45	Diff. washers small	2	x	x		
46	Balls 1/8 "	24	x	x		
50	O-Rings 15 mm	2	x	x		
51	Diff. washers large	2	x	x		
46	DIFF. BALLS 1/8 "	24	x	x	1008	Fl. 2.95 \$ 1.50

Draw no	Description	Qty	SP12	PRO10	Part no.	List Price
47	THRUST BEARING	1	x	x	75911	Fl. 6.95 \$ 3.00
48	DRIVER PLATE	1	x		75841	Fl. 7.95 \$ 3.50
49	BALL BEARINGS 1/4 X 3/8	2	x	x	1124	Fl. 27.00 \$ 12.00
52	GEAR 80 Tooth	1	x	x	2280	Fl. 13.50 \$ 6.50
53	REAR AXLE	1	x		75861	Fl. 85.00 \$ 40.00
54	LEFT WHEEL PLATE	1	x		75821	Fl. 7.95 \$ 3.50
55	BALL BEARINGS 7 X 11	2	x	x	11260	Fl. 27.00 \$ 12.00
56	BEARING HOLDERS	6	x	x	75930	Fl. 9.95 \$ 4.50
57	LEFT WHEEL INSERT					see clip set
60	FRONT WHEELS	2	x		75801	Fl. 9.95 \$ 4.50
61	FRONT WHEEL AXLE	1	x		75851	Fl. 11.25 \$ 5.00
63	KINGPIN	1	x	x	75770	Fl. 11.25 \$ 5.00
64	KINGPIN SHIMS					see screw spare set
65	CLIPS 2 mm					see clip set
66	STEERING BLOCKS		x	x	75791	Fl. 11.25 \$ 5.00
66r	Steering block right	1	x	x		
66l	Steering block left	1	x	x		
	TRACKROD SET		x		1017	Fl. 15.95 \$ 7.00
67	Trackrod balls	2	x	x		
68	Screws 2 x 6	2	x	x		
69	Ball links	2	x	x		
70	Inserts	2	x	x		
71	Screws 3 x 3	2	x	x		
72	Screw 2 x 10	1	x	x		
73	Center nut	1	x	x		
74	Trackrods	2	x			
75	Nut M 2	1	x	x		

Description	Qty	Part no.	List Price	
BATTERY CONNECTOR SET		1630	Fl. 11.50	\$ 5.50
Corally plugs	2			
Battery sockets	10			
CORALLY PLUGS	3	1634	Fl. 11.50	\$ 5.50
BATTERY SOCKETS	10	1631	Fl. 5.95	\$ 2.75
WIRE CONNECTOR SET		1632	Fl. 12.50	\$ 5.50
Corally plugs	2			
Wire sockets	6			
WIRE SOCKETS	6	1633	Fl. 6.50	\$ 2.50
DAMPER SYRUP	1	80000	Fl. 7.95	\$ 4.00
SOLDERY TAGS	20	1750	Fl. 3.95	\$ 1.70
SILICONE WIRE 2 x 60 cm		1615	Fl. 9.95	\$ 4.00
DECALS, CORALLY/PK 5 sheets/different colors			Fl. 8.00	\$ 3.40
WHEEL DECAL 1,silver		1490	Fl. 3.95	\$ 2.25
WHEEL DECAL 2,silver		1491	Fl. 3.95	\$ 2.25
WHEEL DECAL 1,silver		1492	Fl. 3.95	\$ 2.25
WHEEL DECAL 2,silver		1493	Fl. 3.95	\$ 2.25

CORALLY PINIONS & SPUR GEARS

Normally gears are moulded, and therefore will not be exactly true. You will notice that, when you try to adjust the play between the pinion and the gear. There is always a spot which is very tight, and a spot which has more play.

Therefore the CORALLY gears are cut one by one, which gives a very precise tooth form, and the gear is as true (=round) as possible.

CORALLY pinions are made of stainless steel, and are also machined for the same reason. This results in a very efficient pinion - gear mesh, giving the highest speed and accelerating.

The material of the gears has taken a lot of research, but this has resulted in an ideal material, that combines strength and efficiency, and runs very quiet.

The Balls in the gears are placed in a special way: 6 balls go in one side, the other 6 from the other. This keeps the gear steady, it can't wobble side ways. The amount of balls (12) and the large diameter where they are placed in, make the diff run very smooth with less slip.

Description	Qty	SP12	PRO10	Part no.	List Price	
PRECISION MACHINED PINIONS & GEARS MODULE 0.5						
14 Tooth pinion	1	x	x	2214	Fl. 17.50	\$ 8.50
15 Tooth pinion	1	x	x	2215	Fl. 17.50	\$ 8.50
16 Tooth pinion	1	x	x	2216	Fl. 17.50	\$ 8.50
17 Tooth pinion	1	x	x	2217	Fl. 17.50	\$ 8.50
18 Tooth pinion	1	x	x	2218	Fl. 17.50	\$ 8.50
19 Tooth pinion	1	x	x	2219	Fl. 17.50	\$ 8.50
20 Tooth pinion	1	x	x	2220	Fl. 17.50	\$ 8.50
21 Tooth pinion	1	x	x	2221	Fl. 17.50	\$ 8.50
22 Tooth pinion	1	x	x	2222	Fl. 17.50	\$ 8.50
23 Tooth pinion	1	x	x	2223	Fl. 17.50	\$ 8.50
24 Tooth pinion	1	x	x	2224	Fl. 17.50	\$ 8.50
25 Tooth pinion	1	x	x	2225	Fl. 17.50	\$ 8.50
26 Tooth pinion	1	x	x	2226	Fl. 17.50	\$ 8.50
27 Tooth pinion	1	x	x	2227	Fl. 17.50	\$ 8.50
28 Tooth pinion	1	x	x	2228	Fl. 17.50	\$ 8.50
77 Tooth gear	1	x	x	2277	Fl. 13.50	\$ 6.50
78 Tooth gear	1	x	x	2278	Fl. 13.50	\$ 6.50
79 Tooth gear	1	x	x	2279	Fl. 13.50	\$ 6.50
80 Tooth gear	1	x	x	2280	Fl. 13.50	\$ 6.50
81 Tooth gear	1	x	x	2281	Fl. 13.50	\$ 6.50
82 Tooth gear	1	x	x	2282	Fl. 13.50	\$ 6.50
83 Tooth gear	1	x	x	2283	Fl. 13.50	\$ 6.50
84 Tooth gear	1	x	x	2284	Fl. 13.50	\$ 6.50
85 Tooth gear	1	x	x	2285	Fl. 13.50	\$ 6.50
86 Tooth gear	1	x	x	2286	Fl. 13.50	\$ 6.50
87 Tooth gear	1	x	x	2287	Fl. 13.50	\$ 6.50
88 Tooth gear	1	x	x	2288	Fl. 13.50	\$ 6.50
89 Tooth gear	1	x	x	2289	Fl. 13.50	\$ 6.50
90 Tooth gear	1	x	x	2290	Fl. 13.50	\$ 6.50
91 Tooth gear	1	x	x	2291	Fl. 13.50	\$ 6.50
92 Tooth gear	1	x	x	2292	Fl. 13.50	\$ 6.50

	Part no.	List Price	
WHEELS & TIRES, MOUNTED AND TRUED , SP12			
FRONT			
PK Green	14512	Fl. 27.50	\$11.00
US Green			
PK Blue	14511	Fl. 27.50	\$11.00
US Blue			
PK GOLD	14516	Fl. 31.50	\$13.00
Extra High Bite Japanes 1 PAIR			
PK Silver	14517	Fl. 31.50	\$13.00
High Bite Japanese			
TRC Radial	14613	Fl.	\$
Oval - Concrete, capped tyres			
REAR			
PK Green	14502	Fl. 29.50	\$12.00
US Green			
PK GOLD	14506	Fl. 31.50	\$14.00
Extra High Bite Japanes			
PK Silver	14607	Fl. 31.50	\$14.00
High Bite Japanese			
TRC Radial	14603		
Oval/Concrete, capped tyres			
TIRES ONLY			
FRONT			
PK Green	1412	Fl. 12.50	\$ 8.50
PK Blue	1411	Fl. 12.50	\$ 8.50
PK Gold	1416	Fl. 12.50	\$ 8.50
PK Silver	1407	Fl. 12.50	\$ 8.50
PK Silver	1417	Fl. 12.50	\$ 8.50
TRC Radial	1413	Fl.	\$
REAR			
PK Green	1402	Fl. 12.50	\$ 8.50
PK Gold	1406	Fl. 12.50	\$ 8.50
PK Silver	1407	Fl. 12.50	\$ 8.50
TRC Radial	1423	Fl.	\$

MOUNTING INSTRUCTIONS

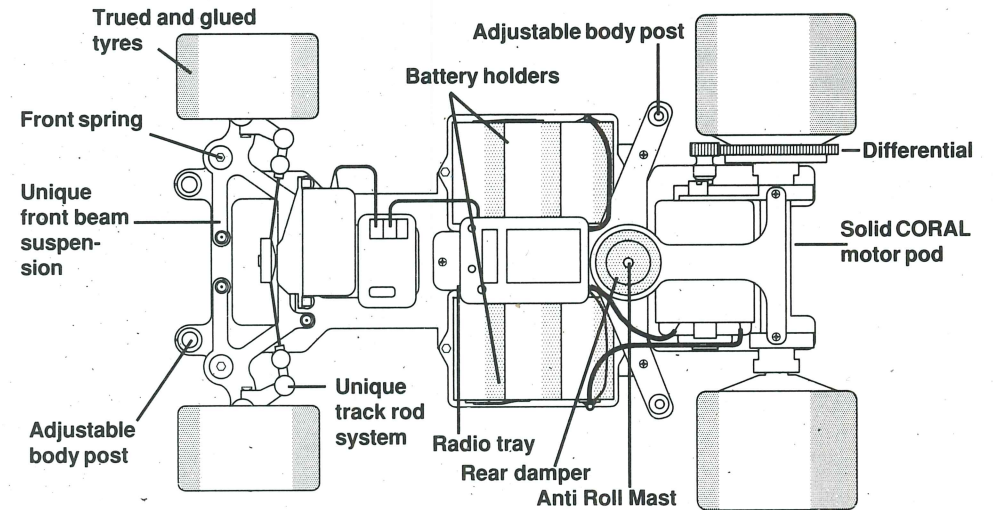

Servo.

The servo posts are mounted with 2 screws M3 x 8. The position of the servo posts is based on the use of a Futaba 32 or a Novac servo. These servo's are the best we know for 1/12th racing, because they are very fast and reliable. The servo itself is fixed to the posts with 2 or 4 screws M3 x 6.

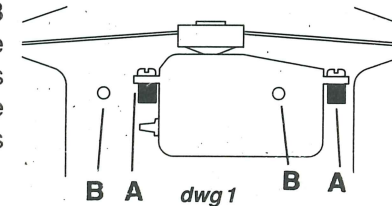

As a servo saver we advice the Kimbrough saver.

Take the 2mm screw and screw it in the centre hole from the front side (dwg 2), then mount the centre pivot.

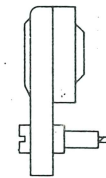

The trackrods are to be mounted as follows:

The trackrod which goes along the longest side of the servo, is to be mounted first, then comes the other one. The loop in the track rod points up-wards (see dwg 3). Stick the other side of the track rod trough the brass insert of the plastic pivot socket, and tighten the set screw. The final adjustments will be done later. (see toe-in)

The track rods have a bit of play on the centre pivot. This is done on purpose, please let it be that way, or you will end up with a bad handling car!

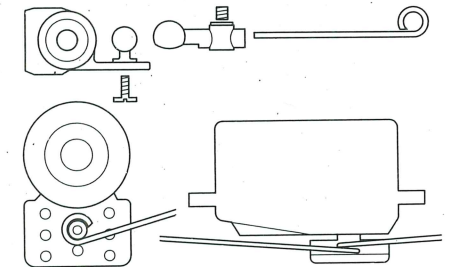

dwg 3

Receiver.

We advice to place the receiver next to the servo, so the radio equipment is as far away as possible from battery, motor and speed controller.

Degrease the bottom of the receiver and the chassis at the place where you want the receiver to be placed. Use a piece of double sided sticking tape to mount the receiver in place.

To mount the receiver wire to the anti roll mast, take the top and the 3 'O'rings of the mast. Stick the wire trough one of the 'O'rings, and press the ring over the mast again, so the wire is kept along the mast by the 'O'ring. The same is to be done with the other two 'O'rings. Slide one 'O'ring to the top, one to the middle and one at the bottom of the mast, thus keeping the wire in place.

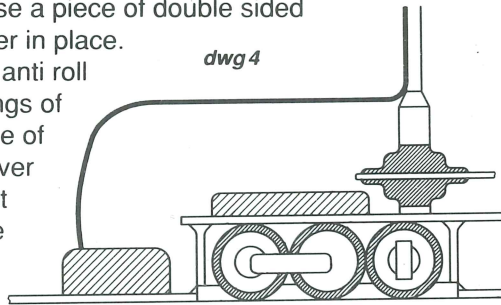

Speed controller.

Mount the speed controller on top of the radio tray. This way the wires are as short as possible, resulting in less electric losses. Also positioning the controller as far away as possible from the receiver prevents interference.

Remember that Corally also can supply the best gold plated plug system to connect your battery to the controller. Ask your dealer!

Battery.

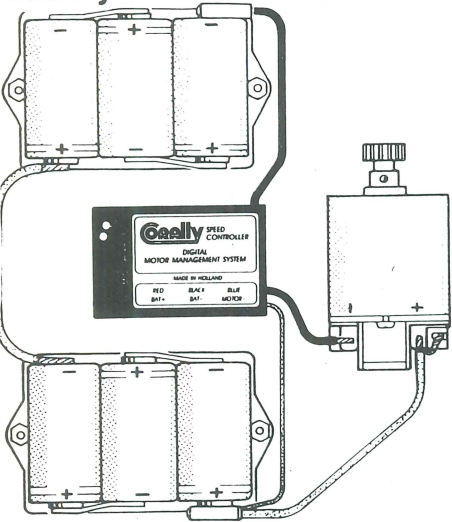

The Corally cars are provided with a smart battery holder system, which makes changing of the batteries easy, but does not put the chassis under any kind of strain.

To fit the cells into the holders:

place the car upside-down on the table, and mount the holders to the under-side of the chassis, so the holders are kept flat by the chassis. (mounting the holders to the underside gives you easy acces to the cells.)

Apply some C.A.glue to the holders, at the spots where the cells will touch the holders. Put the cells in place,

each cell the other way around as the cells beside it (dwg 5). Also apply some glue between the cells themselves. Solder the connection between the cells as shown in dwg 5.

After you have mounted a motor of your choice, and have charged your battery, you can connect the complete electric system according to your manual of the radio equipment and the speed controller. Remember to take the servo saver apart from the servo before you switch on the radio system. Then place all trims on the radio at neutral, and put the servo saver in place again, as close to the neutral position as possible.

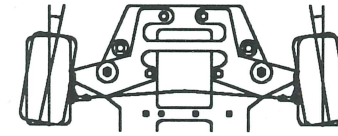

dwg 6

Toe-In.

Now you can adjust the toe-in of the front wheels

The easiest way to do this is as follows:
Turn on the transmitter and the receiver. (Preferably disconnect the motor wires, or remove the motor pinion, so the car can't drive away from you!)

Put the steering trim knob in the centre position and check if the servo saver is exactly vertical. If not, adjust the position of the saver with the steering trim knob of the transmitter till it is.

Place the car side ways on a table, so the car rest on the side of the rear and the front wheel. Unscrew the set screw of the track rod pivot ball at the side that rests on the table. Press the frontwheel flat on the table, and tighten the set screw again.

Now turn the car around so the other side is at the table, and adjust the other track rod in the same way.

Things to know about your car

What is CORAL?

CORAL is a hardened light metal, which has equal characteristics in all directions. This is contrary to fibre glass and graphite, which are made of layers. As the layers at the top contribute more to the strength of the chassis than the layers in the middle, (compare with sandwich construction), these materials will have more flex into one direction than in the other. A CORAL chassis is always straight, and does not become weaker after some time, which makes the handling of the car much more consistent.

Tweak:

Tweak is the most common problem in racing. A car is "tweaked" when the left wheel of one axle has a different weight than the right wheel on the same axle. This makes the car handle different in left and right corners, e.g. over steering to the left and under steering to the right.

The Corally T-bar is mounted on balls, so it can roll freely in the length axle of the car. This combined with the front beam suspension, gives the car not only superb handling, but also makes the car tweak-free. Also the Corally rear friction-plate damper works in all directions with the same force.

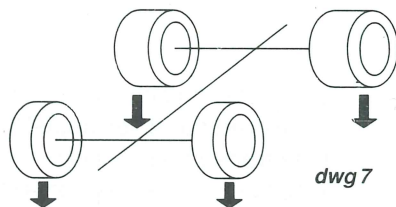

Adjusting the car to different tracks:

Standard position of the T-bar is suited for most tracks, provides the most grip at the rear, and makes the car handle very stable.

On tracks with more grip, you alter the height of the T-bar pivot balls and the angle of the T-bar.

Two washers under the front- and one under the rear pivot ball, gives less chassis-roll, giving more response to the steering.

On very high bite tracks, you can mount 3 washers at the front and two at the rear pivot balls.

If you have too much steering, use front tires with less grip, to make the car easier to handle. Standard supplied with the kit are green tires front and rear. So if you need less grip at the front, use the blue front tires. On most tracks our PK Gold and

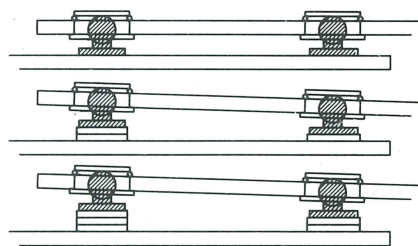

dwg 8

Silver tires work very good, and they wear less than the green tires. Normally the Gold tires have more grip than the Silver. Use this information to find the right set-up of your car.

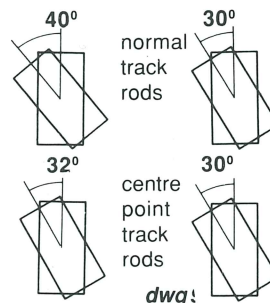

Centre point steering:

A car cornering fast, has little weight on the inside front wheel. Therefore the maximum angle between the wheel and the actual direction the car is going to, is smaller than of the outside wheel, which has more load. If that angle becomes too big, the wheel drags instead of rolls.

The centre point track rods give the inside wheel a smaller angle related to the outside wheel, than a normal track rod system would do, and therefore give less drag,

resulting in higher cornering speed and a less abrupt change from over- to under steer when giving less throttle.

Front wheel turn:

For a good handling car the front wheels must turn the least amount necessary to get around the track. If the front wheels turn too much, you will find it difficult to handle the car under speed. So use the dual rate on your transmitter to give the exact amount of turning and no more! Also changing the position of the centre pivot of the trackrods gives more or less steering. Positioning towards the axle of the servo gives less steering, and a position further away from the axle gives more.

Caster:

If the front wheels wear more at the out-side of the wheel than at the in-side, you can place one or more 3mm washers under the front pivots of the front beam to give some extra degrees of caster. Normally this is not necessary, only on some very high bite tracks.

Ride height adjustment front:

At the front each steering block is mounted with 3 washers. By changing the position of these washers you can change the ground clearance at the front.

Take care to have the same position of the steering block at the right and the left side of the car.

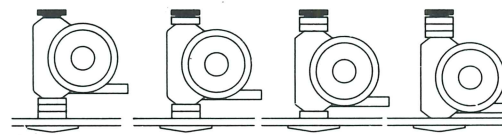

dwg 11

Ride height adjustment rear:

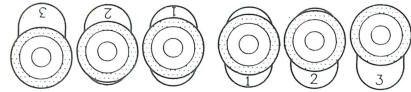

At the rear, there are 3 different sets of ball bearing holders, each with a different position of the bearing, so you have 6 positions to choose from. Take care to always have the same holder in the same position at the left and the right.

Rear damper.

A very important part of the car is the rear damper. When this is not working properly, the car won't handle well.

Normally you don't have to do much about it, but from time to time take the damper apart, and clean it thoroughly. Mount it again and put some damper syrup into it, so the inner system is completely covered by a layer of the syrup. (Do not fill it completely!). Check the working of the damper by taking the damper plate apart from the power pod and moving it by hand in all directions. Damper action should be smooth.

Rear axle:

Provided with the car are some rear axle shims. Normally they are not needed, but if necessary they can be used to adjust the play of the rear axle. If possible, use the same amount of shims at the left- and at the righthand side.

Body:

Mount the body to the car before you paint it, so you can see through it, to easily mark the positions of the holes for the body posts and the antenna.

Before you start spraying the body, you put some tape on the out-side of the body to cover the holes. This will prevent the paint from spraying through the holes and covering the out-side of the body.

Body height is very easy to adjust with the two threaded collars of the body posts. The body posts have a steel insert for the mounting screw, so the thread won't strip. Body posts are available in 3 sizes: 50, 65 and 80mm (2, 2.5 and 3.25")

CORALLY Differential SP12.

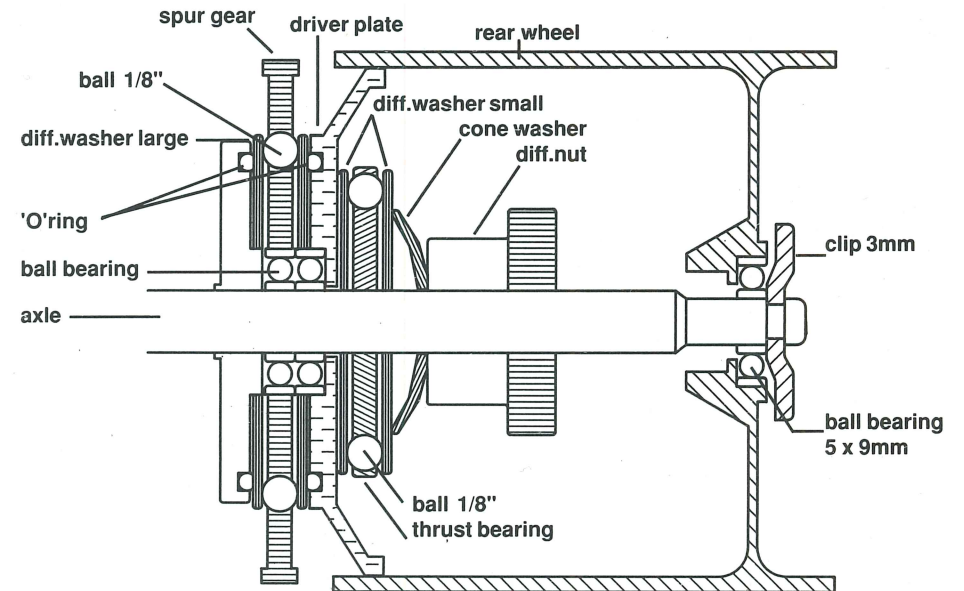

Disassembly:

Take away the clip that keeps the right wheel on the axle, and remove the wheel. Unscrew the black differential nut from the axle.

You can now take apart the differential, watch carefully the order in which the parts are mounted.

The gear has 12 balls (1/8"), 6 are put in place from one side, and 6 from the other. This construction makes that the gear won't wobble side-ways!

The steel diff. plates are kept from slipping by the use of two rubber 'O' rings. This can only work properly if the rubbers as well as the steel washers are totally free from grease! So take care to degrease these parts before assembling.

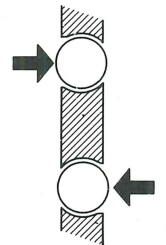

dwg14

Adjusting the diff.

After assembling the differential, put the left wheel in place, keep the left wheel and the driver plate (right) from turning and try to spin the gear. If the gear slips, when applying normal force to the gear, tighten the diff. nut till you are satisfied. The diff. nut should be as loose as possible, without the diff. slipping when pulling away with full throttle. After some practise you should be able to feel by hand how the diff should be adjusted after assembling it.

INTERFERENCE

Nowadays batteries, motors and controllers are so powerful, that you should take extra care with the radio equipment to prevent interference.

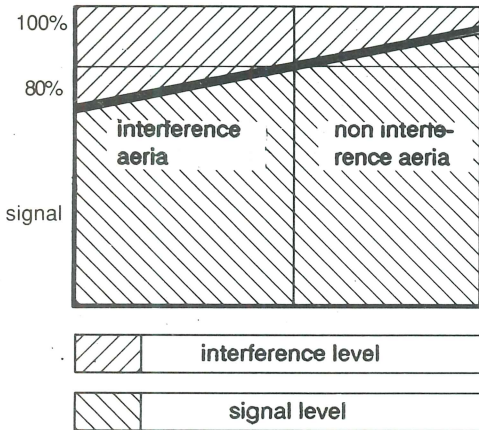

To understand interference, you must know that interference is a matter of adding all bits of interference, coming from different sources. The receiver can handle a certain amount of interference without you noticing it, till the interference becomes too much, and then you "suddenly" have interference. To make it easy to understand, we can give the following "law":

Your receiver can only work properly as long as you have less then +/- 20% interference signal.

There are the following notorious interference sources:

- Motor**
- Battery**
- Speed controller**
- Battery wires**
- Static electricity**
- Damaged crystal**
- Radio and receiver not adjusted to each other**
- Interference from other radios**

All these things give a bit interference. As soon as the total of these interferences exceeds 20%, you will have interference. Changing one of these interference sources might cure your problem, but sometimes it's not enough. Suppose your crystal is damaged, and it acts as an interference source. When you change the crystal, but you also have a bad motor which gives a lot of interference, you will say "it's not my crystal, I've changed it and it's still the same."

Changing only the motor might also not be enough, but changing both might do the trick. This makes interference problems so difficult to solve.

Therefore make sure that all things you can do to minimise interference are done, so when something happens that gives you more interference, your equipment can handle this.

As a rule, you must keep the radio equipment as far away as possible from the motor, batteries, speed controller and wires.

We have very good results by placing a shield between the receiver and the battery (-wires). This shield you must make of a type of metal that can be attracted by a magnet. So no silver paper, but e.g. a piece of a metal cigar case. This must be mounted to the receiver in a way that the receiver cannot "see" the battery, the wires and the controller. Sometimes if you have big interference problems, turning the receiver 90° might help.

Special care should be taken with the aerial wire. The aerial itself should be positioned as far away as possible from the interference sources, and the wire to it also. If your aerial is too long, do not wind it up, but cut it to the length you need. Wrapping it up makes a coil of it, which influences the working of the receiver. The best thing is to have your radio equipment checked by the technical service, who can re-adjust your receiver to operate optimal with an eventual shortened aerial.

The motor you use must have a clean commutator, good brushes and must be suited with 3 capacitors. For more details, see the instruction manual of your motor.

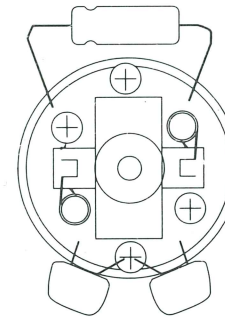

The wires between the battery, the controller and the motor should be as short as possible and as far away as possible from any part or wires from the radio equipment. Especially the wire between the saddle packs should be as short as possible, and far away from the receiver.

We advice to keep this wire under the radio tray, so unscrew the front of the radio tray, lift it a bit and push the connection wire of the saddle packs beyond the front radio tray post, then replace the front screw again.

Crystals are very vulnerable. They can be damaged easily, which can cause interference in some cases. This is very difficult to check, but replacing the crystals sometimes helps when you cannot find an other solution for your problems.



MOTOR MANAGEMENT SYSTEM

At high R.P.M. the torque of an electric motor is low, as is the current. The lower the R.P.M. the higher the torque, but also the higher the Amps are. In principle you can say the higher the Amps, the higher the torque. But at a certain point, more Amps won't give more torque. At that point the armature can't hold any more magnetic flux. Any extra energy that you then would give to the motor, is used to build up heat in the motor, resulting in a very poor efficiency. Also if the battery has to give so many Amps, that will result in early dropping of the voltage and a lower rate of capacity.

To solve this problem, we developed a controller which adjusts the maximum current flowing through the motor; enough to give maximum torque, but not more, to save energy for the last minutes of the race.

The second advantage of the Corally controller is that the energy, the motor generates during braking, is returned to the battery. During braking the motor charges the battery at a pulse rate of 5000 Hz. Its not just the amount of energy that is important but by doing so the efficiency of the battery is increased, resulting in more energy for the race itself.

A great deal of effort went into making the controller more efficient, not only at full throttle, but certainly at half throttle. This again was made possible by our own custom designed chip, which lets the controller utilise a digital system instead of the normal analogue mode. As a result this controller hardly heats, up even under the most difficult circumstances.

The hybrid technology of the controller results in a very rigid and reliable controller, where failure is almost impossible, providing the unit is correctly connected to the battery.

In using digital technology, connecting the controller to your radio equipment is simplified, as you only have to adjust the neutral position of the controller, the rest is always correct

There are so many more functions build in in this device, that it does not deserve the name speed controller, but indeed really is a MOTOR MANAGEMENT SYSTEM. There is also no need to trouble you with other technical specifications usually associated with speed controllers, as they have no bearing on this system. Just mount it into your car, and see how much faster you are. Not only in the first minute, but look at your lap times at the end of the race. Normally your lap times increase after approx. half a race. You will find now that if you are a consistent driver your lap times in the latter part of the race are only some tenth of a second slower than the first laps.

AND THAT MAKES A LOT OF DIFFERENCE !



SUPERIOR PERFORMANCE THROUGH HIGH-TECH ENGINEERING

CORALLY[®]

SP12

As a result of a long and intensive period of research and development we have released the CORALLY SP12.

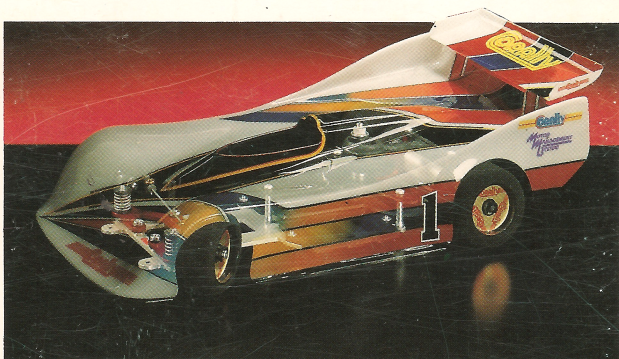

CORAL chassis and front beam, unique rear damper, smooth and slip-free differential, adjustable body posts, saddle pack battery holders, 7 mm rear axle and wobble free wheels.

CORALLY[®]

PRO

The Corally PRO10 can be seen as the big brother of the SP12, with the same high-tech engineering and even more amazing handling.

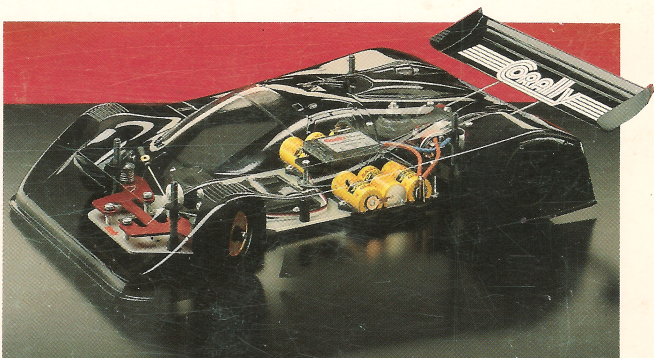

This car is not only ideal for racing on real circuits, but also on parking lots. So you can have your own track just around the corner!

Not included in the kit are: motor, batteries, body and radio equipment. Both Corally cars are completely assembled, incl mounted tires and 9 ball bearings.